

LINELOCK / ROLL CONTROL – PART #LL
Designed for race applications

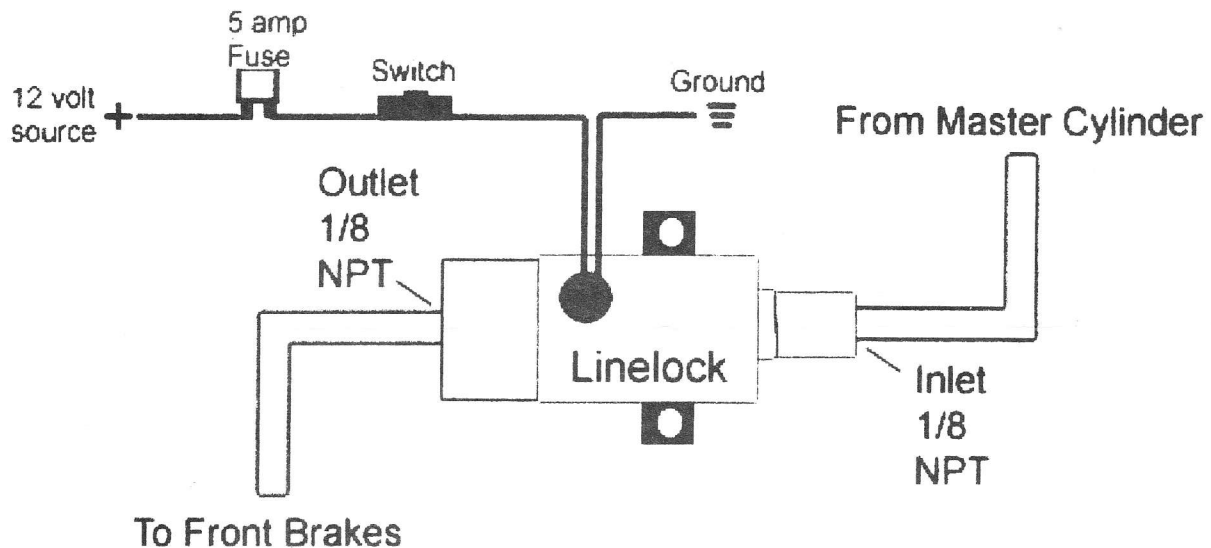

Instructions:

Follow diagram above, LineLock uses 1/8 NPT fittings, different size adapters will be required for all other applications. Adapters not included.

Electrical connections: Either wire can be used, there is no polarity of the wires. One wire goes to ground, the other wire goes to switch. Use 5 amp fuse from the switch to 12 or 16 volt battery source.

We highly recommend that all installations be performed by a skilled mechanic.

Designed for race applications.

NOT RECOMMENDED for use with ABS brake systems.