

Biondo Racing Products

Final Round 2 Stage Controller

Introduction

The 2 stage controller has been designed to operate a throttle stop solenoid but can be used to control any device with up to a 30 amp load such as electric or air shifter or NOS solenoids. Both ON-OFF-ON and OFF-ON-OFF operations can be achieved with this unit. The 2 stage controller has been designed with state of the art technology that eliminates the need for external RF noise suppression and external load resistors required by other units in today's high tech race cars.

Operation

The unit is connected to the transbrake signal. When the transbrake is energized, the 2 stage controller is reset. Upon release of the transbrake, the internal timing unit is started. When the time elapsed equals the time set in the TIMER ON thumbwheel display the output relay will energize. When the total time elapsed equals the time set in the TIMER OFF thumbwheel display, the output relay will de-energize. The unit will always reset when the transbrake is activated. Please note that the time set in TIMER OFF must be longer the time set in TIMER ON for proper operation.

Installation

The unit should be mounted away from heat, vibration, and ignition wires. Fasten the unit with (4) # 6 sheet metal screws in any position. Wire the unit as shown in wiring diagrams. Use proper gauge wire for device being controlled.

Warranty

The 2 Stage Controller is warranted against defective materials and workmanship under normal use for a period of two years as follows. First 60 days, unit will be repaired or replaced free of charge. First year, unit will be repaired or replaced for \$5.00 to cover shipping costs. Second year, unit will be repaired or replaced for \$25.00 flat fee. Send units needing service to:

TAG Systems
Final Round Repair
1737 Rt. 67
Ballston Spa, NY 12020

+12 VOLT OUTPUT
ON - OFF - ON
(RESET - TIMER ON - TIMER OFF)

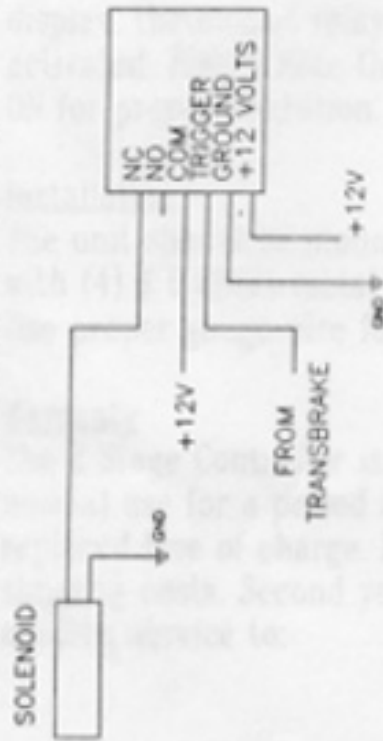

FOR ELECTRIC (UNDER THE CARB)

FIG 1

GROUND TYPE CIRCUIT
GROUNDED - NOT GROUNDED - GROUNDED
(RESET - TIMER ON - TIMER OFF)

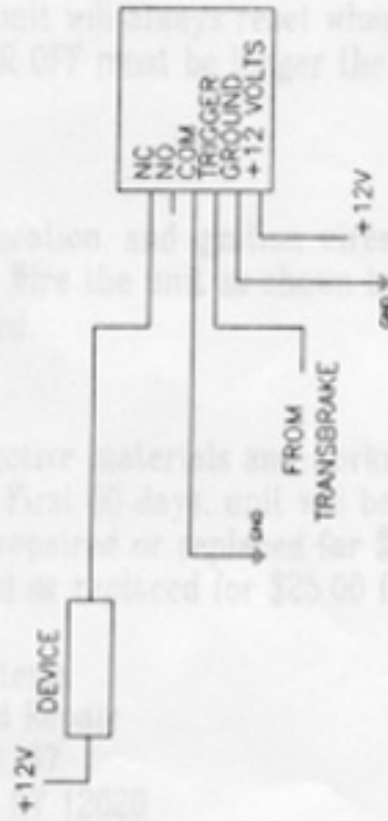
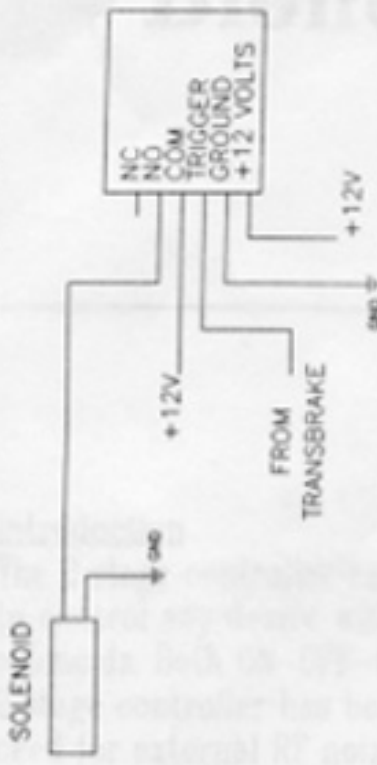

FIG 3

+12 VOLT OUTPUT
OFF - ON - OFF
(RESET - TIMER ON - TIMER OFF)



FOR LINKAGE TYPE

FIG 2

GROUND TYPE CIRCUIT
NOT GROUNDED - GROUNDED - NOT GROUNDED
(RESET - TIMER ON - TIMER OFF)

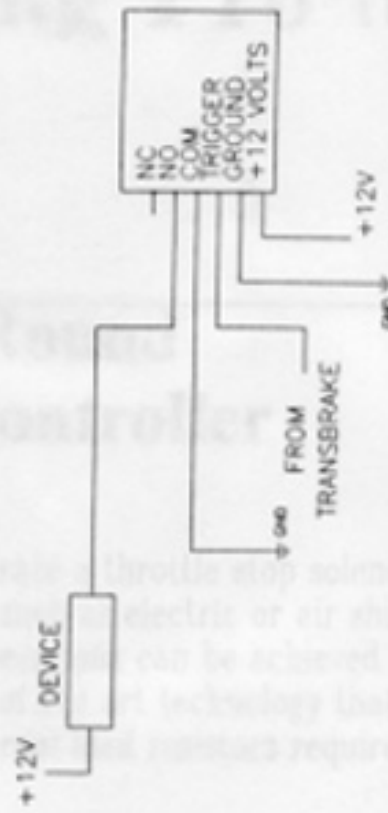

FIG 4

Title 2 STAGE CONT. WIRING DIAG.

Size	Number	TAG SYSTEMS	Rev
C			A
Date	7/16/93	Drawn by	YG
File no.	25CWD	Sheet	1 of 1